

# STATUS OF THE GEOTHERMAL INDUSTRY IN AUSTRALIA

Burns, K.L.<sup>1</sup>, C. Weber<sup>2</sup>, J. Perry<sup>3</sup> & H.J. Harrington<sup>4</sup>

1. Los Alamos National Laboratory, Los Alamos, NM, USA.

2. Pacific Power Corporation, Sydney, NSW, Australia.

3. Ergon Energy, Barcaldine, QLD, Australia.

4. Regional Geologist, Canberra, ACT, Australia.

**Key words:** Australia, electric power production, geothermal resources, geothermal substance, ground source heat pumps, Hot Dry Rock, Organic Rankine Cycle engine.

## ABSTRACT

Hydrothermal power production is centered on serving isolated communities in the Great Artesian Basin. In Queensland, the binary plant at Birdsville has passed long-term trials, and is approaching full-time operation under new management. Production at Mulka Station, in South Australia, has been discontinued. Hydrothermal direct use continues in the Otway Basin of western Victoria, in a district space heating system at Portland, and at a planned new spa at Mornington. Production of industrial hot water at Traralgon, in the Gippsland Basin of eastern Victoria, has been discontinued. Ground and water source heat pumps have been widely adopted for air conditioning throughout Australia, with at least 2000 installations in place. In Hot Dry Rock technology, temperatures at depth in the continent have been assessed, and two field projects are underway in New South Wales (NSW). Near Muswellbrook, drilling has commenced on a full-scale demonstration project, aiming for a depth of 3.5 km. Near Woronora, field trials of hydraulic stimulation of fractures in a Carboniferous granite will be conducted at a depth of about 2 km.

## 1. INTRODUCTION

For two decades prior to 1997, development of Australian geothermal resources consisted of under-utilized hydrothermal systems, used for commercially marginal spas or let run to waste; water-source heat pumps used for air conditioning buildings around Sydney Harbour; and feasibility studies of deep-seated Hot Dry Rock (HDR) in the Cooper Basin of the continental interior.

In 1992, Australia signed the United Nations Framework Convention on Climate Change. A National Greenhouse Response Strategy was developed to address Australia's obligations under the convention. On 20 November 1997, the Prime Minister, the Hon John Howard MP, in a statement 'Safeguarding the Future: Australia's Response to Climate Change', announced a series of measures designed to reduce emission of greenhouse gases. In December 1997, Australia agreed to the Kyoto Protocols at the Third Conference of Parties. By the time frame 2008-2012, it was agreed to limit the growth of greenhouse gas emissions to no more than 8% above 1990 levels. This placed Australia with Norway and Iceland amongst those allowed to increase emissions above

the 1990 baseline.

Since 1995, the geothermal situation in Australia has changed dramatically. The expansion of activity was driven in part by the demonstrated practicality of binary hydrothermal power plants, the commercial success of ground source heat pumps and increasingly, by government support of initiatives to reduce emissions of greenhouse gases.

## 2. HYDROTHERMAL POWER PRODUCTION

### 2.1 Hydrothermal Resources

The Great Artesian Basin is known to geologists as the Eromanga Basin. It covers a considerable part of the continental interior and has a simple layer-cake stratigraphy of Late Triassic to Late Cretaceous sediments usually one to two kilometers thick. It is underlain by stacks of smaller basins of Cambrian to Early Triassic age, the most important in terms of heat resources being the Cooper Basin, containing Permian and Early Triassic sediments.

The basin in its lower part has permeable quartzose sediments, which are the intake beds for surface waters in a humid part of the State of Queensland. The water moves slowly westwards for 1500 to 1600 km and after about two million years emerges naturally in mound springs in the desert on the opposite side of the basin near Lake Eyre.

About half the natural recharge is tapped by 3100 flowing artesian bores and over 35 000 non-flowing. Over some large regions the bore water reaches the surface at temperatures close to 100°C. Bottomhole temperatures (BHTs), at depths of about 1000 m, are 4°C to 5°C higher. For pastoral purposes, the water is cooled and distributed by bore drains, which are often tens of kilometers long, and may reach lengths of 90 km. Small homemade power plants used bore pressures to drive simple turbines to produce electricity for homesteads. They gradually become obsolete and only 20 or so survive.

### 2.2 ORC Engine Developments

Organic Rankine Cycle (ORC) engines in Australia were initially developed by Enreco (Energy Resources Corporation) Pty Ltd for Solar Pond applications. Several prototype engines were built for the demonstration solar pond at Alice Springs, Northern Territory (NT), between 1981 and 1986. These prototypes were the basis for further ORC engine developments using geothermal hot water from the Great Artesian Basin, at Mulka and Birdsville (localities in Figure 1).

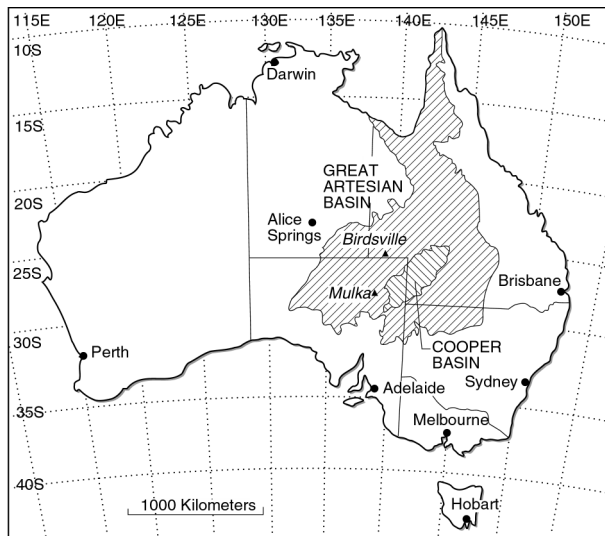

Figure 1: Australia, showing the Great Artesian Basin. Adapted from Sawyer, 1991, Fig.2; also Energy Information Centre (EIC), 1986, p.3.

### 2.3 Mulka, SA

Mulka Station is a cattle ranch on the Birdsville Track in northeastern South Australia (SA), near 138°39'E and 28°20'S. A second 15 kW ORC engine was built in 1984 and 1985 by Enreco in Adelaide, funded by the Government of South Australia (SA), and installed at Mulka.

The bore is approximately 500 m from the homestead and was drilled in 1904. It is 1300 m deep and supplies water at 86°C and 500 kPa. The bore was refurbished by the SA Department of Mines and Energy in 1985 and an 80 mm-diameter fiberglass casing was cemented in the top 300 m, restricting the flow rate by approximately half to 10 L/s. An earlier generating system on the site consisted of two 8kVA single phase generating sets. They were capable of producing approximately 4 kW in midsummer when the ambient temperatures rise to 50°C.

The layout of the ORC system is shown in Figure 2. Three cooling ponds were constructed as clay-lined "turkey nest" dams, two for the ORC engine and one for the station stockwater system. The two for the ORC engine comprised a larger pond providing recirculating water to the condenser and a smaller pond for makeup water. There was no separate source of condensing water, such as rainwater. So condensing water was obtained by using the water, which had already passed through the ORC engine and feeding it into the first pond. The first pond enabled initially hot water to cool to ambient temperatures and this then became makeup water for the main condensing water pond. Cool water was drawn from the bottom of the pond through 100mm-diameter polyvinyl chloride (PVC) pipe and pumped through the condenser. The water was then recirculated to the pond through a 40m-long floating sprayer system.

The Mulka plant was commissioned on May 17, 1986 and ran virtually non-stop for three and a half years (32 000 hours). It was believed to be the first operational geothermal

power system in Australia and the lowest operating temperature system in the world.

The average electrical output far exceeded the average station load of 3.5 kW. In very hot weather the ORC output was limited by condensing temperatures and 10 kW was the capacity under these conditions. Gross conversion efficiency was 8% with a net of 6% when parasitic loads were taken into account. Frequency stability and response to load changes was comparable to diesel installations with similar hydraulic governing systems.

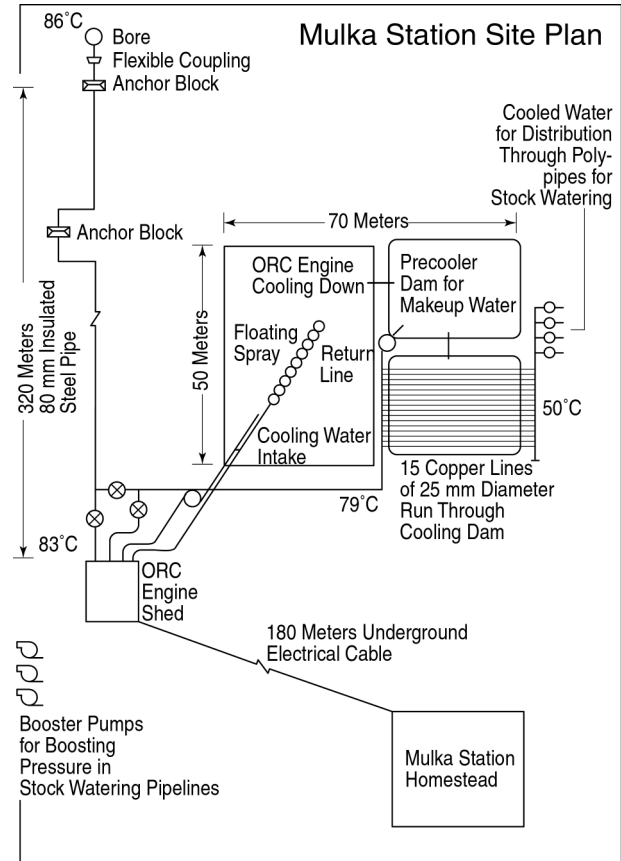

Figure 2: Mulka Station Site Plan. Adapted from Sawyer, 1991, Fig.3.

### 2.4 Birdsville, Queensland

Birdsville is a small isolated town, population 100, in outback Queensland (QLD), at 139°20'E 25°50'S. The maximum power demand is about 250 kW. A free flowing geothermal well in the town taps into the Great Artesian Basin. It has been flowing for some 45 years. The depth of the bore is 1221 m and the aquifer depth 1173 to 1220 m. The bore casing is a nominal 6 inch diameter and the flow is about 30 L/s with a shut in pressure of 1213 kPa.

A power plant (Figure 3) was financed by the National Energy Research and Demonstration Council (NERDDC), an agency of the federal government, now the Energy Research and Development Corporation (ERDC). The Queensland Electricity Commission (QEC) was the project manager, and output was distributed through the Capricornia Electricity Board. Enreco Pty Ltd of Alice Springs built the plant under

a fixed-price contract. The plant was rated at 150 kW gross or 100 kW net output. This plant was an eight-fold scale up of Mulka, and demonstrated Enreco's technology for supplying the whole power needs of inland towns in the Artesian Basin.

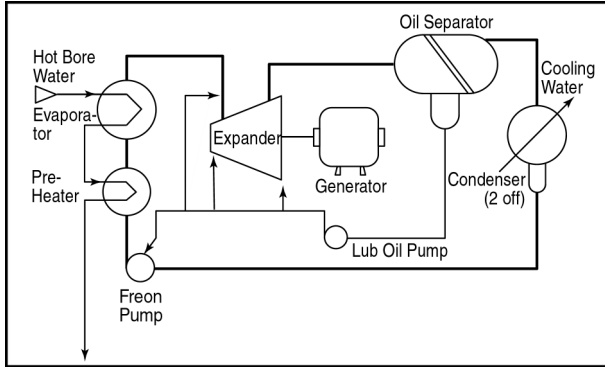

Figure 3: Birdsville 120 kW ORC plant, schematic drawing. Adapted from Perkins, 1994

The contract was let in November 1987; construction of the unit began at the workshops of the SA Gas Company in Adelaide in November 1988. It was pressure tested by June 1989, then disassembled and freighted to Birdsville. After a number of teething problems, the plant commenced operations in October 1992. The plant ran for approximately 9000 hours to the end of 1994. Average net output was about 60 kW, with an average 39 kW of parasitic load. From October 1992 to June 30, 1994, the plant produced a net 207 MWh, which was fed into the town grid. This was equivalent to 76 000 liters of diesel oil.

Performances measured at different operating levels are shown in Table 1. The system as first built was capable of 150 kW but Perkins thought parasitic losses of 40 kW were irreducible, so the net power output would be unlikely to exceed 120 kW. He thought the best opportunity for improved performance was to replace the Freon with a more volatile working fluid.

Table 1: Birdsville geothermal power plant. Operating data at generator output close to 80 kWe. Numbers in brackets are from simulations. The evaporator outlet temperature was assumed to be reading 4°C too high, and was adjusted accordingly. The bore water flow meter reading was suspected to be about 4% low, but was not adjusted. From Perkins (1994).

Working fluid flow L/s	7.6
Working fluid flow kg/s	(11.05)
Evaporator outlet pressure kPa(abs)	1051
Evaporator outlet temperature °C	97.5
Expander inlet pressure kPa(abs)	880
Pressure after full expansion kPa(abs)	(228)
Condenser pressure kPa(abs)	319
Bore water flow L/s	28.4
Bore water inlet temperature °C	97.5
Bore water outlet temperature °C	83.0
Heat extracted from bore water kW(h)	1723
Generator power output kW(e)	82.2
Parasitic power kW(e)	40.3
Thermodynamic efficiency %	4.77

Operations were suspended because the working fluid, Freon, had become environmentally unacceptable due to depletion of the ozone layer. The QEC was incorporated as the Queensland Transmission and Supply Corporation (QTSC) and was then dismembered.

In 1997 ownership of the Birdsville plant passed to Capricornia Electricity Corporation of Rockhampton, which is now Ergon Energy. They provided funding for the plant to be refurbished by Enreco and several new hydrocarbon working fluids were tested. Isopentane proved the most suitable as its lower pressure and higher volume allowed full use of the oversize screw expander. It had a higher expansion ratio and proved significantly more efficient than R114 as the engine working fluid. Its lower pressure also reduced parasitic liquid pump power requirements by 10 kW. Tests in 1999 confirmed the overall potential of the geothermal/ORC electric system with the new working fluid.

The plant was put back on line on June 28th, 1999. By September 1st, the plant had completed 10 000 hours of operation. Performance in the first two months, to August 30, was approximately 1100 hours on line, 44 000 net kWhr, 74.4 kW gross average output, 39.0 kW net average output, and 35.4 kW parasitic average load.

A full test program was planned for the rest of 1999 to replace some ORC engine components, such as the condenser plate heat exchanger and throttle valve, which were optimized for R114 rather than isopentane, and to bring the plant up to full capacity. Funding for these upgrades was provided by the Queensland Office of Sustainable Energy.

The ORC plant will be connected to the new Birdsville diesel station. A unique feature will be its ability to operate automatically in a standalone mode, loadsharing as part of the Birdsville grid. If this is successful, there are many other small communities in the Great Artesian Basin that would be candidates for this technology.

### 3. HYDROTHERMAL HOT WATER SYSTEMS

The district heating system at Portland, in the Otway Basin of western Victoria at 141°38'E 38°21'S is operated and maintained for the Glenelg Shire Council as a local government utility. It draws 65 L/s at 58°C from aquifers in the Dilwyn Formation at a depth of 1400 m. It was described at length by Burns et al (1995). The total energy savings to the Shire were estimated at 8 857 014 MJ per annum, and cash revenues of about \$A350 000 per annum. However, accumulated reserves in 1999 of about \$A2.5M were put to other uses and further expansion was halted.

The Nepean 38 bore near Sorrento, on the Mornington Peninsula at 144°19'E 38°22'S, had a thermal gradient of 69.4 mK/m. It produced water at 50°C at a depth of 534 m from an aquifer in the Tertiary Nirranda Group of the eastern part of the Otway Basin (King et al, 1985). During 1999, developers received approval from the local government to build a hot water spa in the vicinity.

In the Gippsland Basin of Victoria, near Traralgon, at 146°32'E 38°12'S, water was recovered at 68°C from a depth of 600 m in two wells. It was used for process water in paper manufacturing by Australian Paper Manufacturers (APM),

now AMCOR, in the 1950s (Cull, 1979). It appears that geothermal operations throughout this basin were terminated by massive dewatering of the region due to expansion of brown coal mining operations (King et al, 1985).

**4. HEAT PUMPS**

Probably the first water-source installation was an air-conditioning system for the Australian Mutual Provident (AMP) Society building on Sydney Cove, in the 1960s. The most recent water-source installation on Sydney Harbour was the Finger Wharf Apartments, where 120 meters of coiled piping delivered geothermal air-conditioning to 34 harborside luxury apartments.

The largest single ground source heat pump (GSHP) system installed in Australia was the air conditioning system at the new building of the Australian Geological Survey Organisation (AGSO) at Simonston, near Canberra (149°08'E, 35°18'S). This carried water through loops of pipe buried in 350 bore holes 100 meters deep. The ground temperature averaged 17°C. Water-to-air heat pumps were installed throughout the building, each serving up to four perimeter offices or eight interior offices. Each of the 220 pumps was independent, and could be switched off if not in use or switched on after hours if that part of the building was occupied. However, laboratories required conventional air conditioning because of varying heat loads and the need to provide make-up air for fume cupboards. The net present cost advantage of this geothermal air conditioning system over a base variable air volume air conditioning system was calculated to be \$A936 219 over a 25 year plant life.

Other large GSHP installations include a detention center (jail) in Dubbo, NSW. Investments by ERDC include systems for heating commercial quantities of hot water and systems to dry fruits and vegetables. The Australian market is expanding by more than 50% per annum. The number of residential systems installed is now more than 2000.

The coefficient of performance (COP) is the ratio of energy available for cooling or heating to energy consumed to drive the system. Conventional air conditioning systems are about 3.3. Research which would raise the COP of a typical ground source heat pump system from 4 to 6 is being conducted by collaboration between the Australian National University and Melbourne University at the Advanced Engineering Centre for Manufacturing (AECM), by using paraffin wax as a phase change material on either side of the pump within a geothermal system.

**5. HOT DRY ROCK RESOURCES**

Geothermal provinces in the Australian continent were established by Sass & Lachenbruch (1979). The heat is derived from radiometric crustal sources in the western and central provinces, and is augmented by heat of mantle fusion in the eastern highlands.

Research aimed at evaluation of Australian resources of Hot Dry Rock was started in 1994 by ERDC with the collaboration of AGSO; the Geothermal Program, Australian National University; the Centre for Petroleum Engineering, University of New South Wales; and the Electricity Supply Association of Australia.

At AGSO, the continental dataset GEOTHRDD was compiled, containing the bottom hole temperatures (BHTs) of 3475 boreholes. Temperatures at a depth of 5 km below each borehole were determined by linear extrapolation, using the two conductivities of sedimentary cover and basement. A map of the continent, on Lambert conformal conic projection, was published by Somerville et al (1994, Fig.7.2). The data was replotted on a rectangular latitude-longitude grid, and published by Hot Rock Energy (HRE) Pty Ltd (1997, Fig.5 p.9). The data is very noisy, especially in Eastern Australia. A manually smoothed version (Figure 4) was issued in Cawood (1996), Naryan and others (1998, Fig.3 p.833), and was the basis for HRE (1997, Fig.6 p.10). The result agrees generally with the geothermal gradient map of Cull & Conley (1983, Fig.7 p.333).

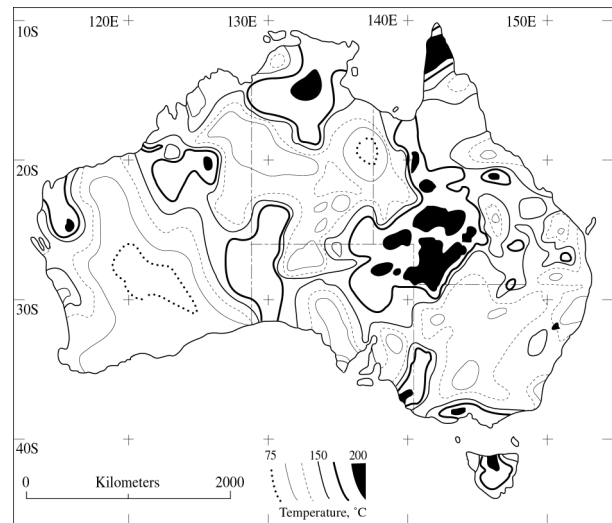

Figure 4: Geothermal Resources Map. Temperature at a depth of 5 km in Australia. Contours 75, 100, 125, 150, 175, and 200°C. Redrawn from Cawood (1996), after Doone Wyborn and Prame Chopra of AGSO. Reproduced courtesy of Australian Geographic.

An assessment based on the BHT data yielded the resource base. The method of derivation described in Wyborn et al (1995) may be written in Iverson notation (Burns, 1996, p.28) as follows.

$$Q_{hp} = \int \{C(T - T_r) [T > T_a] [Z \leq Z_d]\} dV$$

$Q_{hp}$  is the HDR power resource, integrated over a rock volume  $V$  for which the initial temperature  $T$  is known by interpolation for all points of depth  $Z$ .  $C$  is the average volumetric heat capacity of the rock,  $T_r$  is the rejection temperature,  $T_a$  is the acceptance temperature, and  $Z_d$  is the drilling cutoff depth. This is a resource estimate, and takes no account of extraction costs or conversion efficiencies. Somerville et al (1994) chose  $T_a = 225^\circ\text{C}$ ,  $T_r = 165^\circ\text{C}$ ,  $Z_d = 5$  km, and used  $C = 2.2$  PJ per cubic kilometer per  $^\circ\text{C}$ , where PJ is a petajoule, or  $1\text{E}+15$  joules.

The total Australian resource base was estimated at 22.723 MPJ, with a surface area of 229 520 km<sup>2</sup>, and a rock volume of 344 228 km<sup>3</sup>. Over 80% of the resource was found to be concentrated in central Australia, extending over the north-eastern corner of South Australia and the south-western corner of Queensland. Much of this region is essentially coincident with the Cooper Basin, an infrabasin below the Great Artesian Basin. This is in the central radiometric province of Sass & Lachenbruch (1979).

**6. MUSWELLBROOK HOT DRY ROCK PROJECT**

The first Australian effort in Hot Dry Rock (HDR) was a study of the feasibility of producing power for a gas pipeline compressor station in the Cooper Basin of South Australia, by Santos Ltd, a petroleum corporation (Haines, 1984). Geothermal gradients varied from 51.1 to 52.3 mK/m (Middleton, 1979).

In March 1995, Hot Rock Energy Pty Ltd (HRE), was established as a research and development corporation by The Broken Hill Proprietary Company Limited, Western Mining Corporation Ltd, Halliburton Energy Services Group, Baroid Drilling Fluids Inc., Bovis Australia, University of NSW, Commonwealth Scientific and Industrial Research Organisation (CSIRO) Division of Petroleum Resources, Fallon Group, Cape Range Ltd, Tasman Research Pty Ltd, Wilkie Teape & Co, Hamilton Agriculture Pty Ltd, Energy Australia, and Earth Energy Pty Ltd.

The New South Wales Department of Mineral Resources (DMR) recognized the status of Hot Dry Rock as a Group 8 mineral, meaning that the resource may be explored under the mineral rights of the Crown, and development cannot be resisted by individual owners of surface property rights. The first Crown exploration license was put out for competitive bid in 1998.

Pacific Power Corporation was awarded an exploration license for five years over the Hunter Geothermal Anomaly, near Muswellbrook, in the upper valley of the Hunter River, in eastern New South Wales (Figure 5), where geothermal gradients range up to 65 mK/m. An exploration drilling program commenced on April 12, 1999.

**6.1 Definition of a Geothermal Substance**

On the 22 May 1998, the New South Wales Mining Act was extended to include exploration for geothermal substances. A regulation was issued under the Mining Act 1992, which revised the definition of mineral (Governor of NSW, 1998). Under the regulation, "... a geothermal substance is a reference to any substance occurring naturally underground that is heated by the natural processes of the earth to a temperature in excess of 100 degrees Celsius (other than any other substance referred to in those Schedules, and other than petroleum, coal, oil shale and uranium)." This amendment was issued in order to extend the definition of geothermal resources from hydrothermal to hot dry rock (Mullard, 1998). The regulation resolves for New South Wales the long-standing issue of whether a geothermal resource is a property or a substance. Above a certain temperature, a rock with that property becomes a new substance, a geothermal substance.

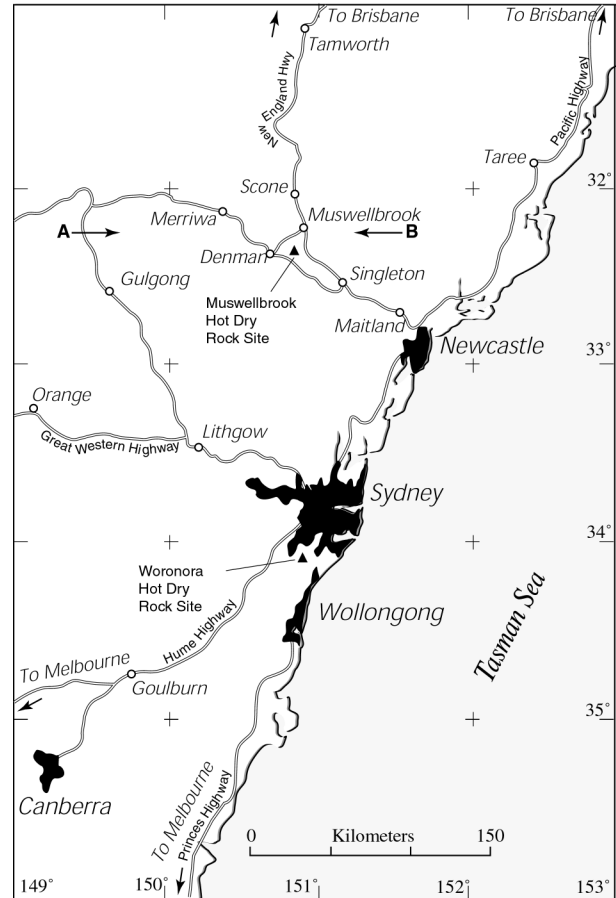

Figure 5: Hot Dry Rock (HDR) Project Location Map. Location of the Muswellbrook and Woronora HDR sites.

**6.2 The Hunter Geothermal Anomaly**

The Hunter Geothermal Anomaly lies in the Hunter Coalfield in the Northern Sydney Basin. Exploration wells are 1 = Amoco Wybong; 2 = Amoco Goulburn River; 3 = Australian Oil & Gas (AOG) Martindale; 4 = Amoco Big Adder Hill; 5 = Pacific Power Randwick Park (previously Elecom Hunter Randwick Park, EHRP 1); 6 = Pacific Power Llanillo (previously Elecom Hunter Llanillo, EHL 1); and 7 = Esso Jerrys Plains (Figure 6 and Table 2).

Table 2: Temperature gradients in exploration bores. (\*) indicates a continuous temperature log

Name of Bore	Depth (m)	BHT (°C)	Gradient (mK/m)
3.AOG Martindale	1179	57	32
2.Amoco Goulburn River	565	47	48*
1.Amoco Wyong	762	54	45*
4.Amoco Big Adder Hill	656	55	47*
5.PP Randwick Park(a)	608	48	52
6.PP Randwick Park(b)	555	52	64*
7.PP Llanillo	763	65	65
8.Esso Jerrys Plains	1595	61	26

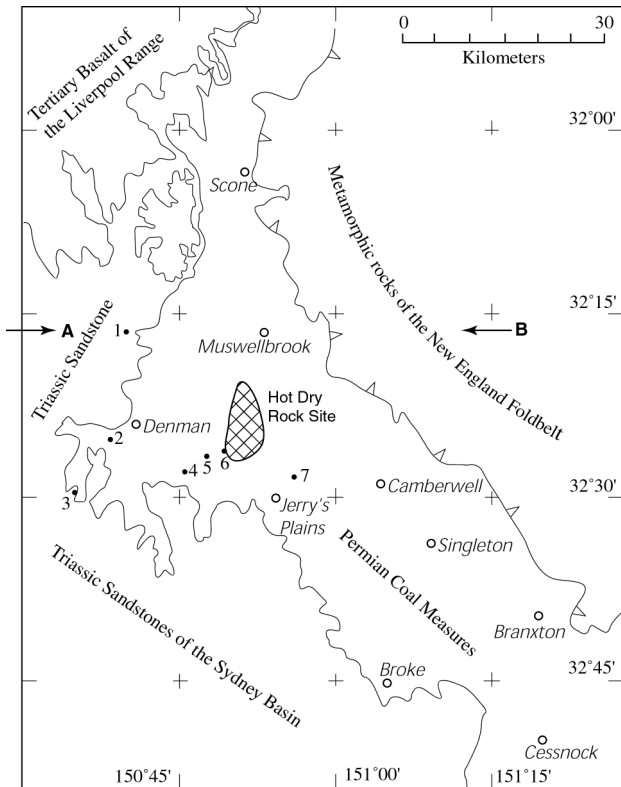

FIGURE 6: Geological Map. General geology of the project area. The crosshatched area is the Hunter Geothermal Anomaly. After Weber (1998, Plan 5).

The Hunter Geothermal Anomaly was discovered by Pacific Power Corporation in the course of a coalbed methane survey in 1991 (Wyborn et al, 1995, p.8; Odins et al, 1995). Odins et al (1995) modeled the source as radiometric granite in the basement under the coal measures. Their regional section AB through the basin (Figure 7) shows the granite within the basement, beneath a thick sequence of Permian coal measures.

In 1995, Pacific Power Corporation commissioned AGSO to carry out a semi-detailed gravity survey of 4500 km<sup>2</sup> at the site. The results showed a gravity low coincident with the geothermal anomaly. Various definitions of the geothermal anomaly have been issued (boundaries *a*, *b* in Figure 8), and various interpretations of the source at depth (boundaries *c*, *d* in Figure 8).

The geothermal source was estimated to have an area of 50 km<sup>2</sup>, temperature at 5 km of 275°C, depth to top (depth to basement) of 3.5 km, thickness [for  $Z \leq 5$  km,  $T \geq 165^\circ\text{C}$ ] of 1.5 km, average temperature 250°C, volume 75 km<sup>3</sup>, and resource 14,025 petajoules (HRE 1977, Tab.2, after Somerville et al, 1994).

### 6.3 Geothermal Tender Process

The Department of Mineral Resources invited tenders for exploration of the Hunter geothermal anomaly in July 1998 (DMR, 1998). When tenders closed on September 30th, 1998, three tenders were received, from Pacific Power Corporation, Hot Rock Energy Pty Ltd, and the Geothermal

Energy Tender Group. Pacific Power Corporation won the tender with a three-year exploration program, budgeted at more than \$A10 million, over an area of 1000 ha in the Jerrys Plains - Denman area (Casey, 1998). An exploration license for geothermal substances was issued to Pacific Power (boundary *e* in Figure 8). Pacific Power is an electrical producer with investments in green energy including Pacific Solar, Blayney wind farm, Olympic Solar Village, and Burringuck hydro expansion. It operates the Liddell and Bayswater coal-burning power plants, less than 20 km to the northeast, and has property within the geothermal tender area.

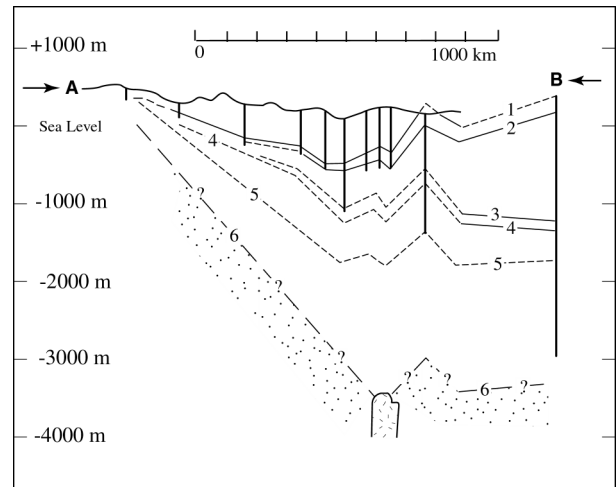

Figure 7: Exploration Section. Regional geological section along the axis of the Hunter embayment, A-B of Figure 6. Point A is approximately 149°35'E 32°15'S. Point B is approximately 151°13'E, 32°17'S. Vertical lines are wellbores. Vertical exaggeration is 250:1. The marker horizons are 1 = Bayswater Seam; 2 = base of the Wittingham coal measures; 3 = base of the Branxton formation; 4 = base of the Greta coal measures; 5 = top of the Allandale formation; and 6 = top of inferred basement. Shown in the basement is the inferred position of a possible high-heat producing granite body responsible for the Hunter Geothermal Anomaly. Redrawn from Odins et al (1995, Fig.4 p.7).

### 6.4 Presently Known

The temperature gradient in the top kilometer is 64 mK/m. There is a north-south string of negative Bouguer gravity anomalies through the center of the exploration license, depth -4 mgal. The areal extent of the gravity anomaly is between 50 and 200 km<sup>2</sup>. Triassic rocks form the escarpment to the west and south. Permian sediments are about 3.5 km deep at the site. There are three main coal measure sequences, Wollombi (up to 50 m thick), Wittingham (270-770 m) and Greta (200-230 m). Under the Greta Coal Measures, the Dalwood Group (about 1600 m), and pre-Permian sediments below that (more than 600 m), are largely unknown. The depth to basement is about 4 km.

The horizontal stress is greater than the load of the overburden in the top kilometer.

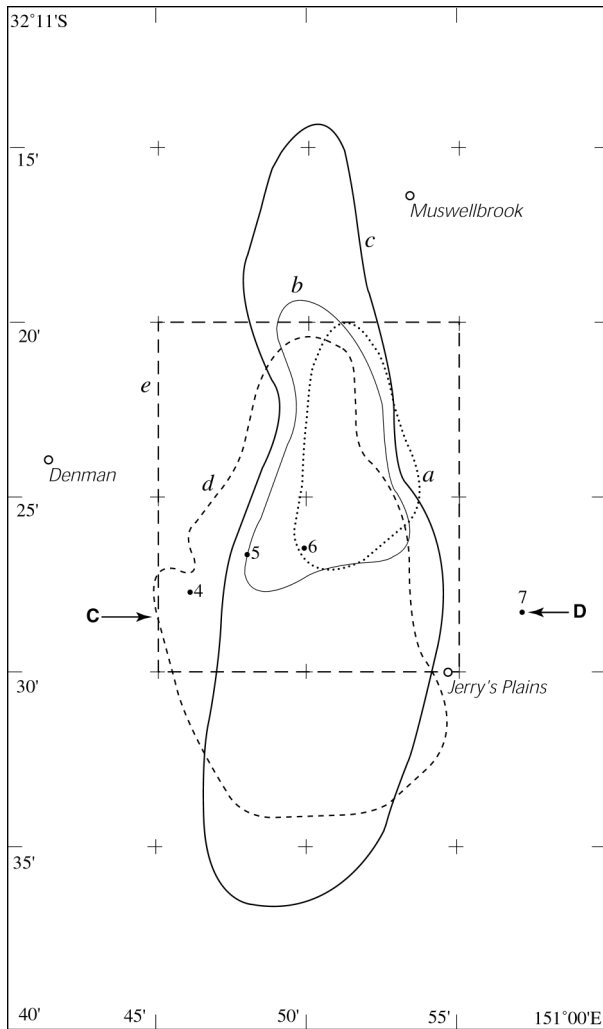

Figure 8: Exploration Map. Plan of the upper reaches of the Hunter Valley, near the towns of Denman, Muswellbrook and Jerrys Plains. Areas *a* and *b* = observed boundary, at the surface, of the Hunter Geothermal Anomaly, after Odins et al (1995, p.6, Fig.2 and Fig.3). Areas *c* and *d* = inferred boundary, in the basement, of the possible source rock, a high heat producing granite in the basement, as shown in section in Figure 7. The boundary *c* is after Odins et al (1995, p.6, Fig.3). The boundary *d* is after HRE (1997, Fig.11 p.16), and Narayan et al (1998, Fig.4 p.833). Boundary *e* = perimeter of the Exploration License. Exploration bores in the vicinity, numbered 4, 5, 6, and 7, are as in Figure 6.

### 6.5 Muswellbrook HDR Project

The Muswellbrook HDR project is being conducted by Pacific Power Corporation, with collaboration of the CSIRO Division of Petroleum Resources and Australian National University. It is proposed to drill a pattern of wells to investigate the site in depth (Figure 9). The work will proceed in stages, subject to periodic reviews of progress. The budget anticipated in the tender submission was \$A1.7M (years 1 and 2), \$A9.1M (year 3), and \$A11.3M (years 4 and 5). The drilling can be divided into four series of wells, here named stages A to D. The stages A to D will be performed in, respectively, Years 1, 1 & 2, 3, and 3 & 4, of the project.

Drilling stage A comprises three exploration wells. The Randwick Park well (1 of Figure 9) may be deepened to 850 m and two new holes (2 and 3 of Figure 9) drilled to 700 and 850 m respectively. The purpose of these wells is to obtain early confirmation in depth of the existence of the geothermal anomaly, the relationship between lithology and temperature gradient, the decay of thermal drilling transients in the ambient temperature field, and to test interwell seismic transmission characteristics in the coalfield.

Drilling stage B, completed in 1999, comprises eleven reconnaissance wells (4-14 of Figure 9), from 300 to 500 m deep, in a pattern extended over the license area. The purpose is to delimit the temperature field and establish horizontal and vertical geothermal gradients for downward continuation.

Drilling stage C is a slim investigation hole (bore 15, not located on Figure 9), to 2-km depth. If not cored, this will be staged in diameter from 8.5 inches (215.9 mm) to 200 m, 6 inches (152.4 mm) to 900 m, and 4 inches (101.6 mm) to 2000 m. This is a pilot for the deeper wells that follow, and addresses issues that will be important in drilling them. A full suite of geological, geophysical and geomechanical studies will be conducted in the hole.

Drilling stage D is a geothermal injection well to a depth of 4 km, drilled in Year 3, followed by a production well to the same depth, possibly at the location 150°48.1'E, 32°25.2'S shown in Figure 9. The injector will be used for massive hydraulic fracturing to create an artificial reservoir. The fracture field will be mapped by microseismic monitors installed in shallow wells nearby. The production well will then be drilled into the reservoir for water circulation tests.

The circulation data will be used to assess the feasibility of a commercial system on the site, producing 10-20 MW of electric power. Should geothermal power be produced, Pacific Power has a Memorandum of Understanding with NorthPower to sell HDR-produced electricity into the green power market.

## 7. WORONORA HOT DRY ROCK PROJECT

The Department of Petroleum Engineering at the University of New South Wales has been engaged in HDR research since 1994. In Phase 1, from 1997 to December 1999, funded by ERDC and industry, studies were made of deep Australian geothermal resources in collaboration with AGSO. Three stress regimes were found to occur in juxtaposition in the area of the Cooper Basin, offering a choice of target areas for potential HDR development. Laboratory and numerical studies, aimed at developing optimized stimulation strategies, examined hydraulic stimulation of reservoirs, and shear dilatation methods for opening fractures.

Phase 2 is funded by the Australian Greenhouse Office (AGO) and industry, and takes that work into the field at Woronora Well No.1 in the southern part of the Sydney Basin, near 150°56'E, 34°09'S (Figure 5). The bore passes through Mesozoic and Paleozoic strata to enter Carboniferous granite at depth. This will be the first field work undertaken in a buried granite in a reverse fault stress regime, to determine whether a horizontal reservoir can be created. This would be in contrast to vertically extended HDR reservoirs

created at Fenton Hill and Rosemanowes, in different stress regimes.

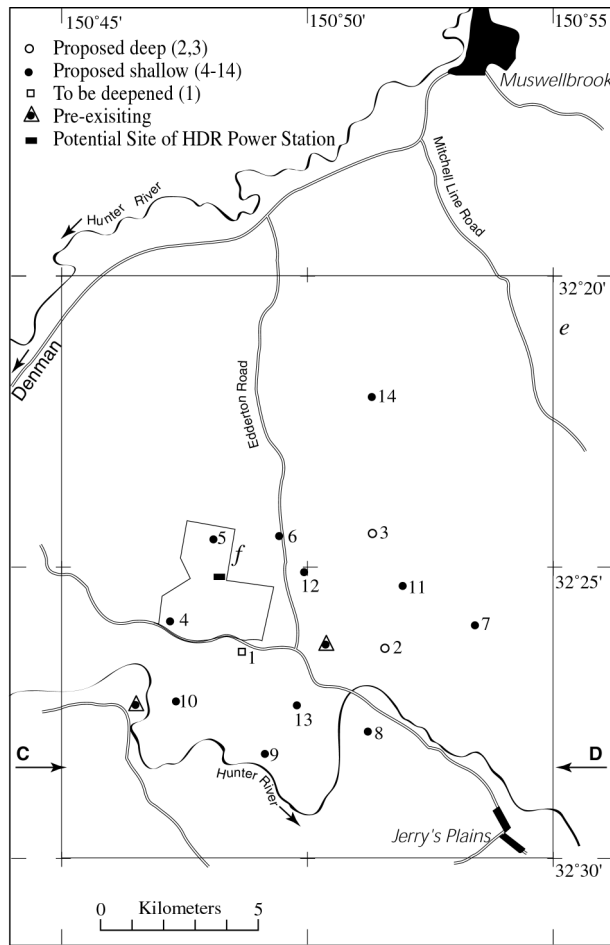

Figure 9: Drilling Program Map. Upper Hunter region, showing the proposed drilling program. Holes 4-7 and 9-14 are shallow wells; hole 1 will be deepened; and holes 2-3 will be new deep wells. A site for hole no.15 is yet to be determined. A possible site for the HDR plant is the solid rectangle at 150°48.1'E, 32°25.2'S. Boundaries are *e* = Exploration License; *f* = Pacific Power HDR Project Area. After Weber (1998, Plan 11).

**ACKNOWLEDGEMENTS**

Information on the bores and water resources of the Great Artesian Basin was kindly provided by Rein Habermehl of AGSO, and on hydrothermal power production by Steve Sawyer of Enreco. The authors are grateful to Neil Buckingham for an update on Portland and a tour of the operations. Gordon Cheyne of AGSO and Richard Metcalf of WaterFurnace provided information on ground source heat pumps. We thank Valerie Reed at Australian Geographic magazine for permission to use Figure 4, and Doone Wyborn and Prame Chopra, at the Geology Department, Australian National University, for information on its derivation. John Hawke, at the NSW Department of Mineral Resources, provided information on the geothermal tender process. We are especially grateful to Ruth Bigio for drawing the figures. Thanks are due also to Rob Jeffrey at the CSIRO Division of Petroleum Resources; Bill Vlahovic and Brenton Smith at

Pacific Power Corporation; and Sumant Naryan, at the Department of Petroleum Engineering, University of New South Wales. We also thank Michael Sandy, Lyn Alexander, Bruce Kilgour, Melanie Marwick, Narelle Jarman, Phil Rawlings, Trim Brant, Chris Reardon, Bruce Fraser, Grant Sheard, Andrew Dickson, and Elaine Osborn.

**REFERENCES**

Burns, K.L. (1996) *Heat Flow and Hot Dry Rock Geothermal Resources of the Clearlake Region, Northern California*, Report LA-13158-MS, Los Alamos National Laboratory, 41pp.

Burns, K.L., R.A. Creelman, N.W. Buckingham, and H.J. Harrington (1995) Geothermal Development in Australia. *World Geothermal Congress 1995, Florence, Italy, 18-31 May 1995*, Proceedings, vol.1 pp.45-50.

Casey, D. (1998) *Hot dry rock tender winner*. Minfo 62, NSW Department of Mineral Resources, St. Leonards NSW, 40p.

Cawood, M. (1996) 21st-century energy - you're standing on it. *Australian Geographic*, No.44, October-December, pp.21-22.

Cull, J.P. (1979) Heat Flow and Geothermal Energy Prospects in the Otway Basin, SE Australia. *Search* v.10 no.12, Dec.1979, pp.429-433.

Cull, J.P. and D. Conley (1983) Geothermal gradients and heat flow in Australian sedimentary basins. *BMR Journal of Australian Geology & Geophysics*, 8, pp.329-337.

DMR (1998) *Tender Information. Hunter Valley, New South Wales, Australia*. July 1998. New South Wales Department of Mineral Resources (DMR), St. Leonards NSW. 7p.

EIC (1986) *Renewable Energy Resources. Geothermal*. Fact sheet no.10, Energy Information Centre (EIC), SA Department of Mines and Energy, Adelaide SA, Australia. 6p.

Governor of NSW (1998) Mining (General) Amendment (Geothermal Substances) Regulation 1998. *New South Wales Government Gazette*, No.81, 22 May 1998, pp.3597-3598.

Haines, R. (1984) *Hot Dry Rock Geothermal Technology: It's Application for a Cooper Basin Development*. August 1984, Internal Report, Santos Ltd., Adelaide SA. 87pp.

HRE (1997) *Hot Rock Energy. Green energy from hot dry rock using heat mining technology*. August 1997, Hot Rock Energy (HRE) Pty Ltd., Sydney, Australia. 24p.

IEA (1997) *Energy Policies of the IEA Countries, 1997 Review*", International Energy Agency (IEA), Paris. p.61, p.265.

King, R.L., A.J. Ford, D.R. Stanley, P.R. Kenley & M.K. Cecil (1985) *Geothermal resources of Victoria - a preliminary study*. Department of Industry, Technology and Resources and the Victorian Solar Energy Council, Melbourne, 129pp.



Middleton, M.F. (1979) Heat Flow in the Moomba, Big Lake and Telachee Gas Fields of the Cooper Basin and Implications for Hydrocarbon Maturation, *Bull. Aust. Soc. Explor. Geophys.*, vol.10 no.2, June 1979, pp.149-155.

Mullard, B. (1998) *Hot Dry Rock*. Minfo 60, NSW Department of Mineral Resources, St. Leonards, NSW. 37p.

Narayan, S.P., D. Naseby, Z. Yang and S.S. Rahman (1998) Petroleum and Hot Dry Rock: Two types of energy sharing commonalities, *APPEA Journal*, pp.830-847.

Odins, P.A., M.A. Bocking and D. Wyborn (1995) 'Hot Rocks' in the Hunter - Prospects for geothermal energy, in R.L. Boyd and G.A. MacKenzie, editors, *Advances in the Study of the Sydney Basin*, Proceedings of the 29th Newcastle Symposium, 6-9 April, 1995, University of Newcastle, Australia, 8p.

Perkins, D. (1994) *The Birdsville Geothermal Electricity Project. Development of a commercial demonstration facility*", Internal Report, Queensland Electricity Commission (QEC), Brisbane, Qld. Date approximate. 11p.

Sass, J.H. and A.H. Lachenbruch (1979) Thermal Regimes of the Australian Crust, in McIlhenny, M.W., editor, *The Earth - Its Origin, Structure and Evolution*, Academic Press, London, pp.301-351.

Sawyer, S.L. (1991) Electricity Generation from Low Temperature Heat Sources Using Organic Rankine Cycle Engines, *1991 Electric Energy Conference*, Darwin NT, 10-13 June 1991, pp.151-159.

Somerville, M., D. Wyborn, P. Chopra, S. Rahman, D. Estrella, and T. Van der Meulen (1994) *Hot dry rock feasibility study*, Energy Research and Development Corporation (ERDC) Report, 94/243, Canberra, ACT. 133p.

Weber, C. (1998) *Jerrys Plains Hot Dry Rock Development Area*, Tender Document, September 1998, Pacific Power Corporation, Sydney NSW. 27p.

Wyborn, D., M. Somerville, M. Bocking and A. Murray, 1995, "Australian Hot Dry Rock geothermal energy potential and a possible site in the Hunter Valley", *Aust. I.M.M. Annual Conference, Newcastle, 1995, Technical Proceedings*, Australasian Institute of Mining and Metallurgy (Aust.IMM), Parkville Vic. pp.31-35.

## APPENDIX

The following tables are a standard form prescribed for Country Updates. Table 4 is omitted, as collective data on Ground Source Heat Pumps is not available. Table 8 is omitted, because accurate estimates of expenditure on geothermal work could not be obtained.

TABLE 1. PRESENT AND PLANNED PRODUCTION OF ELECTRICITY

Numbers in this table are from IEA (1997). No information is available for January 2000 regarding capacity under construction, or funds committed to future construction. The production provided by geothermal plants is negligible (see Table 2), and figures on production from renewable sources are not available.

2005		Total projected use	
January 2000	In operation		
Fossil Fuels	Capacity MWe	32.62	35.52
	Gross Prod. GWh/yr	179.01	195.741
Hydro	Capacity MWe	7.53	7.53
	Gross Prod. GWh/yr	16.185	16.559
Nuclear	Capacity MWe	0	0
	Gross Prod. GWh/yr	0	0
Total	Capacity MWe	40.15	43.04
	Gross Prod. GWh/yr	195	212.3

TABLE 2. UTILIZATION OF GEOTHERMAL ENERGY FOR ELECTRIC POWER GENERATION

The two geothermal electric power production sites, Mulka and Birdsville, are both in the Great Artesian (Eromanga) Basin. There are no other geothermal electric power producing facilities in Australia. The effective date of this table is 31 December 1999. The status is R = retired, N = temporarily not operating. The type of unit is B = Binary (Rankine Cycle). Production at Mulka comprised 32 000 hours from May 17, 1986 to about October 1989. Production at Birdsville occurred in at least two stages. The QEC produced from October 1992 to December 1994. The average net output, when on line, was about 60 kW. Up to June 30, 1994, production was 207 MWh. Based on the last figure, their total production is estimated to have been 269 MWh. Ergon Energy conducted a test from June 28 to August 30, 1999, 63 days, comprising 1100 hours at an average 74.4 kW, producing 81.84 MWh, which is the number in the table. If sustained for a year at that rate, production would be 473 MWh.

Locality	Mulka	Birdsville
Power Plant Name	Enreco	Ergon
Year Commissioned	1986	1999
No. of Units	1	1
Status	R	N
Type of Unit	B	B
Unit Rating kWe	10	150
Total Installed Capacity kWe	10	150
Annual Energy Produced 1999 MWh/yr	0	81.84
Total under Construction or Planned MWe	0	0

TABLE 3. UTILIZATION OF GEOTHERMAL ENERGY FOR DIRECT HEAT

The facility at Portland is the only space heating installation in Australia based on geothermal hot water. Type H = Space heating & district heating (other than heat pumps); there are many air conditioning systems in Australia based on ground or water source heat pumps, for which we have no information. Type B = Bathing and swimming; there are numerous hot water pools at various places around Australia, developed for bathing by local government or tourist resorts, or undeveloped, which draw water from natural hot springs, but no information on heat production is available. The Portland system has a hot water feed, with no steam. Neil Buckingham estimates that the system downtime is from 5 to 10%, for this table we have used 8%. The effective date of this table is 31 December 1999.

Locality		Portland	
Type		B & H	
Maximum Utilization	Flow Rate (kg/s)	90	
	Temperature (°C)	Inlet	57.5
		Outlet	30
Capacity (MWt)		10.4	
Annual Utilization	Ave.Flow (kg/s)	81	
	Energy (TJ/yr)	293.8	
	Capacity Factor	89.6	

TABLE 5 SUMMARY TABLE OF GEOTHERMAL DIRECT HEAT USES

Portland in Victoria (Vic) has the only geothermal space heating facility in Australia, operated by Glenelg Shire Council. It supports 18 990 m<sup>2</sup> of enclosed public space in the downtown area. The Portland system heats 2000 m<sup>3</sup> of water volume in the municipal pool. Bathing and swimming uses at other sites are not quantified. Ground and water source heat pumps support numerous direct heat uses, including air conditioning and agricultural drying, but no quantitative information is available. Industrial process heat production from geothermal sources has ceased at Traralgon, Vic. The effective date of this table is 31 December 1999.

Use	Installed Capacity (MWt)	Annual Energy Use (TJ/yr)	Capacity Factor
Space Heating	96	2712	0.9
Bathing and Swimming	08	226	0.9
TOTAL (Portland)	104	2938	0.9

TABLE 6. WELLS DRILLED FOR ELECTRICAL DIRECT AND COMBINED USE OF GEOTHERMAL RESOURCES

This table applies to the period from January 1, 1995 to December 31, 1999. At least 2000 wells have been drilled for ground source heat pumps in Australia, possibly as many as 4 000, but details are not available. Pre-existing wells were used for geothermal production at Mulka, Birdsville, and Portland, for preliminary heat flow evaluation at Muswellbrook, and will be used for stimulation testing at Woronora. The only specifically geothermal drilling in the period was eleven geothermal gradient wells at Muswellbrook, to depths ranging from 400 to 900 m. No production or injection wells were drilled in the period.

Purpose	Wellhead Temperature	Number of Wells Drilled	Total Depth (km)
		Electric Power	
Exploration	12°C	11	5.62

TABLE 7. ALLOCATION OF PROFESSIONAL PERSONNEL TO GEOTHERMAL ACTIVITIES

Categories are (1) Government, (2) Public Utilities, (3) Universities, (6) Private Industry. Category (4), paid foreign consultants, is omitted. Category (5) is also omitted, as there is probably no contribution of manpower into Australia through foreign aid programs. This tabulation does not include ground source heat pumps.

Year	Professional Person-Years of Effort			
	(1)	(2)	(3)	(6)
1995	1	1	5	2
1996	1	1	6	2
1997	1	1	7	2
1998	1	1	8	3
1999	3	1	9	4
Total	7	5	35	13

End